

Appendix 1 to the R&Mfreenet Warranty Program

1. R&M Certification Process

The R&Mfreenet certification process is three pillars:

- a) Adherence to applicable standards, both for products and installations;
- b) - Installation performed according to the R&M installation guides;
- and “R&Mfreenet Installation and Testing Guidelines for Generic Cabling”;
- c) Visual inspection and test results showing no failures.

Point a) See Chapter “2. Standards”

- Point b) - See “R&M freenet Installation and Testing Guidelines for Generic Cabling”;
- See R&M installation guides

Point c) Visual inspection on 10% of installed links (5% on patch panel and 5% on outlet) for:

- Termination and re-termination according to installation guides Bending radius according to “R&Mfreenet Installation and Testing Guidelines for Generic Cabling”; Cable jacket stripping and untwisting of cable pairs according to EN 50174-1 and “R&M freenet Installation and Testing Guidelines for Generic Cabling”;
- Labeling of components according to EN 50174-1 Cable laying, management, grounding connection according to EN 50174-1 and “R&M freenet Installation and Testing Guidelines for Generic Cabling”;
- The fiber optic measurement must be made with a Power Meter / Light Source according to ISO/IEC 11801 and “R&Mfreenet Installation and Testing Guidelines for Generic Cabling”;
- Back-scattering measurements (OTDR) are used to check components and to locate errors. In special cases OTDR measurements can be recognized as compliance measurements.

1.1. Administrative process for warranty

A complete R&M certification process package is required, consisting of:

- Cabling plans in AutoCad, PDF, RTF, visio format;
- Request for certification document (.doc).
- Worksheet describing material used, where it was used and labeling etc. in excel format;
- Power budget at 850nm/1300nm or 1310nm/1550nm including fiber length, number of connectors and number of splices.
- Complete test report showing all auto test electrical parameters and/or optical parameters (original test equipment measurement data only), and bi-directional measurements.
- The Certification request shall be submitted at latest 6 months after finishing the installation.

2. Standards

2.1. ISO/IEC and EN

- ISO/IEC 11801 2nd Edition : Sept. 2002 (Class D2002 / E)
- ISO/IEC 11801 Ed.2.1 May 2008 (Class E_A channel)
- EN 50173-2; EN 50173-5 May 2007 (Class D2002 / E)
- EN 50174-Series : 2008
- TR 24750 (Channel) 2007

2.2. TIA/EIA-568-B

- TIA/EIA-568-B.2 : April 2001 (Cat.5e = Class D2002)
- TIA/EIA-568-B.2-1 : June 2001 (Cat.6 = Class E)
- TIA/EIA-568-B.2-10 Feb 2008 (Cat 6A channel only)
- TIA/EIA-568-B.3 : April 2000
- TIA TSB-155 March 2007

2.3. IEEE 802.3an 10GBASE-T

R&M guarantees that the transmission characteristics of the channel will comply with the IEEE 802.3an 10GBASE-T:

- Channels composed of R&M Cat. 6 UTP components and installed and tested according to R&M guidelines will reach 55m according to the current standards.
- Channels composed of R&M Real10 Cat. 6 components and installed and tested according to R&M guidelines will reach 100m according to the current standards.

3. Approved Test Equipment

3.1. Copper (Level III & IV Measurement Accuracy)

A certified party must calibrate any test equipment at least once a year.

Class D 2002

Fluke DSP 4000 Series
Fluke DTX Series
Fluke Omni II
Wire Scope 350
LANTEK ® 6 and 7
Wavetek LT 8600

Class E

Fluke DSP 4000 Series
Fluke DTX Series
Fluke Omni II
Wire Scope 350
LANTEK ® 6 and 7
Wavetek LT 8600

Class E_A

Fluke DTX 1800
Wire Scope Pro
LANTEK ® 6 and 7

3.2. Fiber Optic (FO)

All commercially available test equipment complying with the measurement procedure IEC 60874 or similar are admissible.

A certified party must calibrate any test equipment at least once a year.

4. Guaranteed topologies

- Permanent link or channel without CP, **two**-connector model
(Model no. 1);
- Permanent link or channel with cross connect, **three**-connector model
(Model no. 2);
- Fixed horizontal cable or permanent link or channel with CP, **three**-connector model
(Model no. 3);
- Fixed horizontal cable or permanent link or channel with cross connect and CP, **four**-connector model
(Model no. 4);
- “Direct” combined channel
(Model no. 5);
- “Spliced” combined channel
(Model no. 6);
- “Patched” combined channel
(Model no. 7);

	R&M CLASSICsystem Class D 2002	R&M STARsystem* Class E	R&M STAR Real10system** Class E _A	R&M VISIONsystem*** Fiber Optic
Model 1	yes	yes	yes	
Model 2	yes	yes	yes	
Model 3	yes	yes	yes	
Model 4	yes	yes	yes	
Model 5				yes
Model 6				yes
Model 7				yes

* We only give a Class E warranty, if all components in the link are Category 6 or better (R&M STARsystem components).

** We only give a Class E_A warranty, if all components in the channel are R&M STAR Real10 system components.

*** In fiber optic systems the following must be considered:
An increased number of splices and/or connections in a channel can result in length restrictions for the compensation of the additional attenuation.

4.1. Copper topologies

Model 1

Interconnect - TO Model

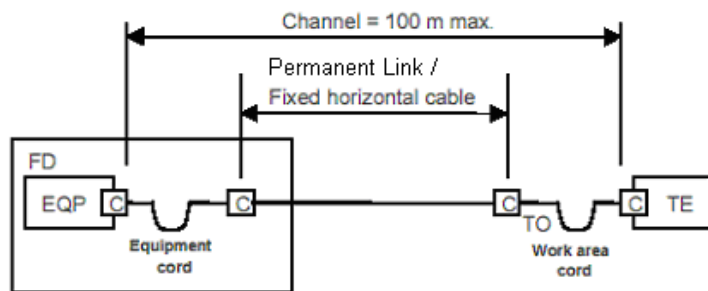

Model 2

Crossconnect - TO Model

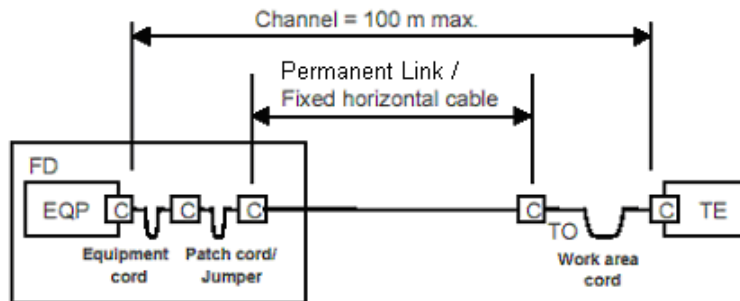

Model 3

Interconnect - CP - TO Model

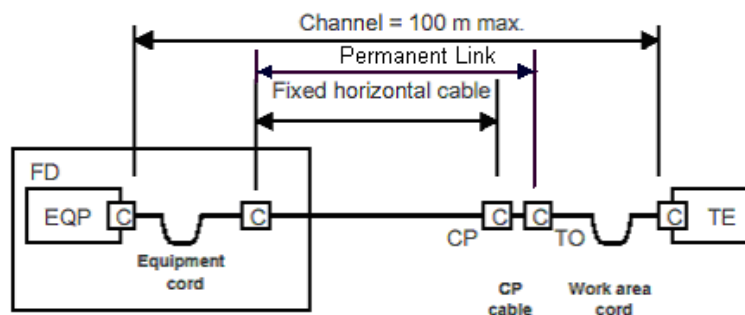

Model 4

Crossconnect - CP - TO Model

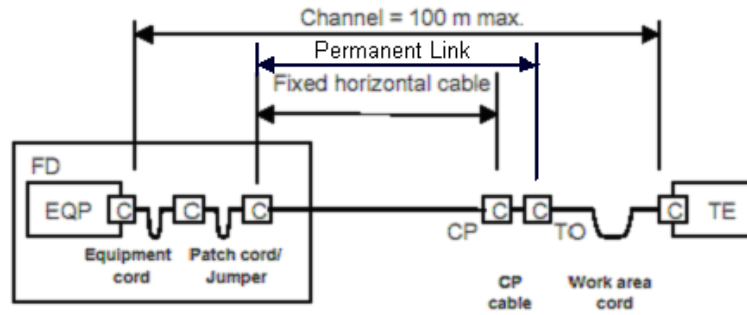

4.2. Fiber Optic Topologies

Model 5

Direct combined channel

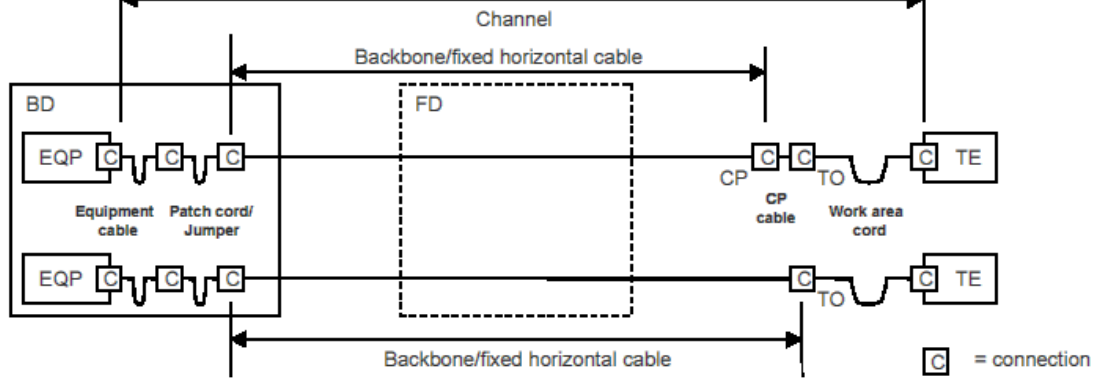

Model 6

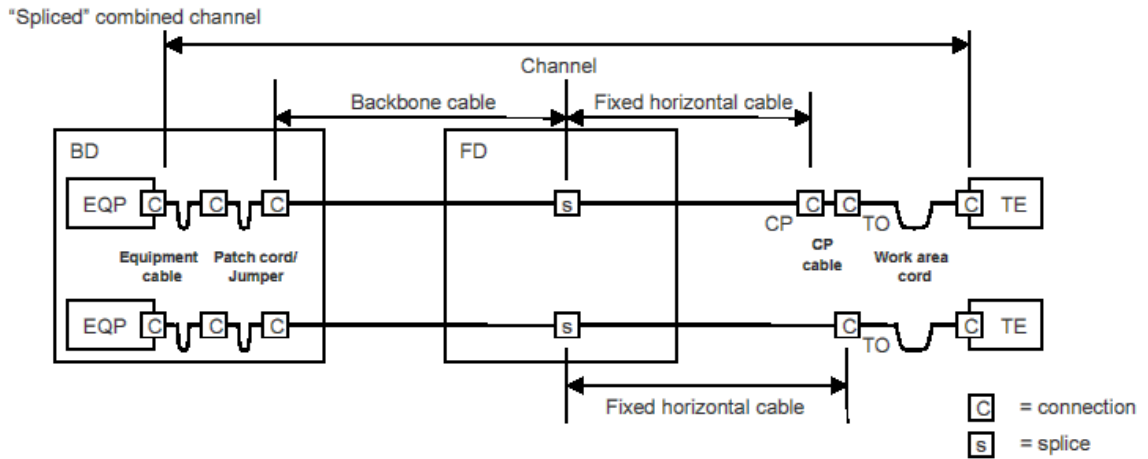

Model 7

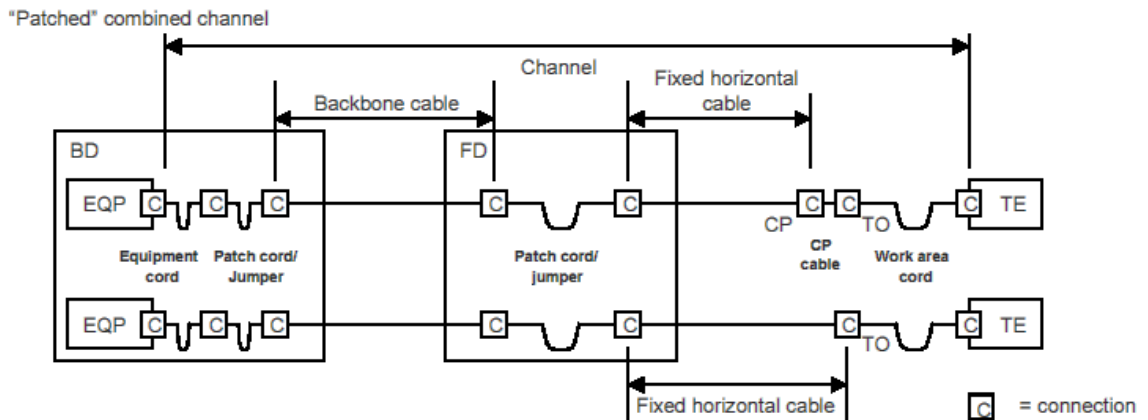

EQP = Equipment

BD = Building Distributor

FD = Floor Distributor

CP = Consolidation Point

TO= Telecommunication Outlet

TE = Terminal Equipment